

A Compound Electric Hybrid Solution

Note: Click on the superscript notations in the paragraphs below to bring up the respective Bibliography segment. To return to that specific paragraph section, click on the same enlarged notation within the Bibliography.

IN-LINE

The **Compound Electric Hybrid** is a straightforward concept similar to the well-known Serial Hybrid or Parallel Hybrid systems featured in many mass-produced cars.^{A1} However, with a Compound Hybrid, the fuel engine and electric motor are positioned in-line and their shafts are connected to one another through a clutch mechanism that controls engagement. As a result, the shafts turn in unison when the clutch is engaged, while only the electric motor output is transmitted to the "transmission" when the clutch is disengaged.^{A2}

The fuel engine and electric motor together constitute the **Primary Power Source** package (or prime mover). To allow for this link-up and compounding, the Electric Motor features a double-ended through-shaft that serves to connect the **Primary Power Source** to the Transmission.^{A3} This setup enables all the **Primary Power Source** output to be channeled directly into an Infinitely Variable Hydrostatic Transmission (IV/HST), which is discussed in more detail upcoming.



INFINITELY VARIABLE

For the Primary Power Source to function as a compounded system, it must be able to adjust RPMs continuously, from a minimum idle or neutral, up to the maximum most efficient RPM point for the requested power output, independently & regardless of the RPMs at the vehicle's drive axles. Therefore, this Compound Hybrid configuration requires the use of an Infinitely Variable Transmission,^{B1} as it allows for low RPM linking up as well as detaching/unlinking between the power source components during vehicle travel at any speed. A geared transmission, on the other

hand, has fixed ratios that tie the vehicle axle RPM to the power source engine(s) RPM, making it impossible to adjust the ratios moment to moment or have infinitely variable ratios, which are needed for compounding to work.

An IV/HST provides the necessary flexibility to link the in-line Power Source components and compound them or unlink them seamlessly. The infinitely variable dynamics enable complete and continuous RPM flexibility between the power source and vehicle axles, allowing for independent mode selection and computerized engine loading at any desired ratio and at any given moment in time. Consequently, the RPMs of the engine(s) are not directly limited or impacted by the speed of the load being moved – even when the load is hardly moving or not yet moving.^{B2}



SWEET SPOT

This compound hybrid application handles all combinations of torque and RPM requirements through the infinitely variable transmission, freeing up the power source package to focus solely on efficiency. The IV/HST transmits torque and RPMs independently of the engine, eliminating the need for a specific torque curve from the engine. This means that engines of any type or fuel can then operate at their most efficient RPM, known as the "Sweet Spot,"^{C1} allowing for greatly improved efficiency. Rather than designing engines with a specific torque curve, designers can focus on creating engines with the best efficiency curve possible (or efficiency area on a fuel consumption map).

This Sweet Spot on the map (or curve) is also referred to as the "best efficiency point" (BEP), which can lead to achieving over 50% engine efficiency, even in heavy truck applications.^{C2} Additionally, any engine, including turbines^{C3}, can be adapted to this compound hybrid, making it a versatile solution. Neither parallel hybrid nor serial hybrid applications can accommodate all BEP possibilities and the incredibly high startup axle torque offered by the Compound Electric Hybrid in all selected drive modes of operation.

SMALL BUT MIGHTY

An Electric motor of only 150KW (like one out of a Tesla Model 3)^{D1} if put in a long-haul Semi-Truck with a Compound Electric Hybrid – can by itself, through the IV/HST final drive, develop 86,000 lb./ft. of torque at the axles!^{D2} This is right from a standstill to the start of rolling the vehicle load, and even while doing a super slow crawl. On level pavement this 150KW motor can also by itself maintain the load at highway speed.^{D3} Additionally the electric motor can reduce its rpm's while the load is in motion and start the fuel engine once the clutch is engaged.^{E4}

Many high-efficiency Fuel Engines are smaller and lighter - while using higher RPM's. Such as the 1.6-liter Formula 1 race engines that produces 700hp with 52% efficiency.^{D4} By focusing solely on efficiency, the typical 15L Semi-Truck engine weighing over 3,000 lbs. can be reduced

to around 700 lbs. while achieving the total horsepower & torque goals with the Compound Electric Hybrid. This weight reduction allows for the addition of batteries without adversely impacting the total vehicle GVW availability.^{D5} In this way, engine designers can make high efficiency truck engines unleashed rather than tethered to the demand for high torque at low RPM's.^{C2}

MAKING HISTORY

Hydrostatic transmissions can be found abundantly over the past century - used in farming and off road equipment, as well as construction equipment, where they are exceedingly valuable for continuously variable speed control while maintaining the power output.^{E1} They have showcased their effectiveness in tackling many challenging tasks with great precision and efficiency, but they have yet to find their place in highway freight truck applications.^{E2} Previous integration of hydrostatics into trucks do not utilize them as the primary transmission pathway from the prime mover to the axle for continuous torque control while traveling on roads.^{E3}



However, by pursuing innovation in this domain and solving the internal limitations of the rotating parts, there is renewed potential for the promise of Infinitely Variable Hydrostatic Transmissions (IV/HST) to emerge as a promising solution for Hybrid technology in trucks.^{F5} With their incredible provision of immediate and sustained high torque during startup and breakaway (even surpassing the capabilities of electric motors).

This IV/HST Compound Hybrid approach allows even a smaller Electric Motor as a component of the Primary Power Source, to deliver & easily maintain by itself an incredible full high torque through the final drivetrain in heavily loaded trucks while crawling at a very slow pace, or even before starting to move.^{E4} Remarkably, this feat can be accomplished without impeding the primary power source's functionality (i.e., lugging an engine) or causing adverse effects on its operation.

HYBRID EXAMPLE TRIP:

From the Spokane Valley to the Port of Seattle, Washington...

SPOKANE VALLEY

The journey from the Spokane Valley to Port of Seattle spans 290 miles on I-90, encompassing a diverse range of elevation changes that total 2,915 feet to climb. Numerous trucks undertake this trip in a day and then back the following day, exchanging loaded trailers carrying various goods and products. Imagine a fully loaded 80,000 lb GVW semi-truck equipped as a Compound Electric Hybrid (C-E-H) embarking from Spokane Valley with its batteries fully charged. It deftly navigates beyond the city limits using just the sheer power of its 150KW electric motor.



AIRWAY HEIGHTS

As the ascent begins, the truck activates its smaller, high efficiency Bio-Diesel engine (ICE) to conquer the 6% grade leading to Airway Heights, where the airports and air base are located. The truck synchronizes the 300KW ICE power with the electric motor. The key distinction here is that the ICE engine consistently runs at an optimal 5,000 RPM, its operating "Sweet Spot". As power requirements vary at the axle, the electric motor reduces or increases its power output, allowing the ICE to maintain this ideal RPM. All thanks to the Compound Electric Hybrid's infinitely variable transmission.



RITZVILLE



Having conquered the grade, the ICE engine continues to operate in its sweet spot, channeling power both to the axles (for maintaining cruising speed), and the balance of power available at any moment goes toward recharging the batteries to their full specification. The rolling hills of farmland enroute to Ritzville along I-90's westward path are now easily managed shifting over to using electric power almost exclusively. Occasionally, the ICE engine is engaged to conquer hills and simultaneously recharge the batteries. Throughout

this routine, the ICE maintains its sweet spot until disengaged, then allowing the electric motor to operate independently.

COLUMBIA RIVER AND THE VANTAGE GRADE

Having journeyed over rolling farmlands, passing Moses Lake, and approaching George Washington, the truck reaches the pinnacle of the Columbia River Gorge. Here, the proactive 'Grade anticipating Smart GPS', has been planning on how to capture all the power available from the upcoming descent. Up to now utilizing battery power often (and operating the ICE at Sweet Spot for travel and recharging needs), it has so planned at this point for the batteries to have been drawn down enough for available room to capture the many kilowatts of power from the upcoming descent. This smart planning ensures recharge battery capacity for the steep descent down the Columbia River gorge, with this descending brake energy (as generated kilowatts) to be stored in the batteries.



ELLENSBURG

With now fully charged batteries, both the electric motor and the ICE engine collaborate to ascend the 7% grade of the Vantage hill on the way to Ellensburg. Following this uphill climb at a good pace, the ICE engine continues to operate solely as needed for axle power and battery charging. The Compound Electric Hybrid dynamic power distribution sustains cruise speed as well as enabling extra power channeled to charge the batteries.



SNOQUALMIE PASS

The climb from Ellensburg to cross over Snoqualmie Pass, encompasses an elevation change of 2,300 feet, and demands more frequent ICE engine activation while also keeping that Sweet Spot higher efficiency advantage. However, as with previous trip segments, the 'Grade Smart GPS' anticipates and plans battery usage effectively. So later when descending the other side of the pass, the truck batteries have already been drawn down enough to capitalize on all the regenerative braking and recharge the batteries fully during the descent.



PRESTON, WASHINGTON, TO SEATTLE: (ZERO EMISSIONS ROUND TRIP)



Having descended from the mountains, the truck proceeds with a full battery charge to pass the city of Preston, located 22 miles outside Seattle. Now switching to electric-only mode and proceeding into the greater Seattle area – it traverses Seattle being a ‘Zero Emissions’ truck. Even during loading and unloading, all the while adhering to an electric-only mode. This emissions-free journey continues until the next day after passing Preston again to climb back up the mountain pass. Then for the climb again with the ICE engine operating solely at its Sweet Spot rpm’s for exceptional efficiency while heading up to the top of the pass.

The Compound Electric Hybrid Truck Primary Objective is Three-fold

Operating at zero emissions within the cities, and zero emissions in lieu of idling elsewhere when stopped, or when slowed down in a traffic jams, or while at a loading dock ... this is the first objective.

The secondary objective focuses on running the ICE engine exclusively at its sweet spot RPMs. By varying the electric motor power output as needed, this constant Sweet Spot can be maintained to have greater efficiency and yielding much higher MPG. And while charging, also significantly reducing GHG emissions per generated kilowatt output when compared to most grid-based “plug-in-your-charger” alternatives.

The third objective centers on harnessing all the potential of downhill stretches to capture the maximum energy from rolling forces while descending. While the ICE engine is off, the electric drive captures downhill energy and stores it in the battery, capitalizing on regenerative braking this way.

TOUTING BENEFITS



The Big Idea: Enable Hybrid Zero Emissions in long-haul semi-trucks, as well as generate electricity with much higher efficiency and a significantly lower carbon footprint than what can be obtained using the average grid, all for a 2,800+ mile range.

As the dawn of Zero Emissions for Heavy Trucks has arrived, the best part per the *Transportation Energy Institute* is that it would demand no upheaval in the existing infrastructure.^{F1} In the freight hauling world it is shown that an electric drive semi-truck consumes around 2.2 KWh per mile.^{F2} Then for the 75 mile range to achieve the status of a Zero Emissions Vehicle (ZEV),^{F3} a battery with an operating range of 165 KWh's is needed to supply this 75-mile "Electric Only" mode of operation. That battery pack would then be a lot like two of the batteries in the basic Tesla Model 3 and weighing around 2,600 lbs.^{F4}

Picture a Semi Truck thoughtfully equipped with this lighter battery pack, (a slight heft over one ton), and realize as the weight of this system dwindles, so does its environmental footprint from inception to finality. (From the cradle to the grave as the analysis is often labeled.)

As shown in the prior "Example Trip", the Compound Electric Hybrid (C-E-H) uses this battery pack in combination with the other Hybrid components to achieve fantastic efficiency, extremely lower carbon footprint, and the Zero Emissions impact where it counts most.

The conventional Series and Parallel hybrids have limitations^{F5} that the Compound Electric Hybrid can overcome. The measures currently being taken to enhance efficiency and reduce emissions of modern diesel engines are compromised by idling and frequent cycling of the engine rpm's. The Compound Hybrid Electric would have more flexibility in its operation - and more metrics, like pressure and flow, for real drive time

analytics along with the data implemented during travel from upcoming grade smart Topographical GPS. So, this Hybrid would intelligently harmonize all operating parameters and thereby facilitate a more efficient operation of the engine and batteries to work in concert and within the coveted "Sweet Spot" ranges of optimum RPM's for both the electric and fuel motors. In addition to enabling the greatest amount of highway "down-speeding" for engine rpms ever imagined. Thus, orchestrating a smart equilibrium within the ensemble of energy use and its distribution to the load.

It is not only about having a very efficient engine – you must also enable high efficiency with very limited high/low rpm cycling, and ‘smart load balancing’ of the fuel engine to keep it in its “sweet spot”. [F6](#) & [C1](#) All of which can be done with a Compound Electric Hybrid and the smart controls easily adaptable in its operation.

All the while - no changes to existing infrastructure are needed to start Zero Emissions now with the Compound Electric Hybrid.

IN SUMMARY

THE COMPOUND ELECTRIC HYBRID:

- 1. Electric-only operation is always available. But whenever the Fuel Engine is running, ensure it consistently operates at the Best Efficiency Point (BEP) rpm.**
- 2. Dynamically manage the Fuel Engine’s power distribution to simultaneously generate electricity and propel the axles, precisely in the required proportions, whenever needed.**
- 3. Equally important, when increased power is needed, add electric power to propel the axles along with the fuel engine.**
- 4. Ensure all these dynamics occur seamlessly, moment to moment, at any speed, on-the-fly while traveling down the road, with no gears to shift.**

MORE DETAILS ON T20E.net:

Bibliography

(Tables, Graphs, References, calculations)

A1

[Plug in Series Hybrid System - ppt video online download \(slideplayer.com\)](https://www.slideplayer.com)

Plug in Series Hybrid System

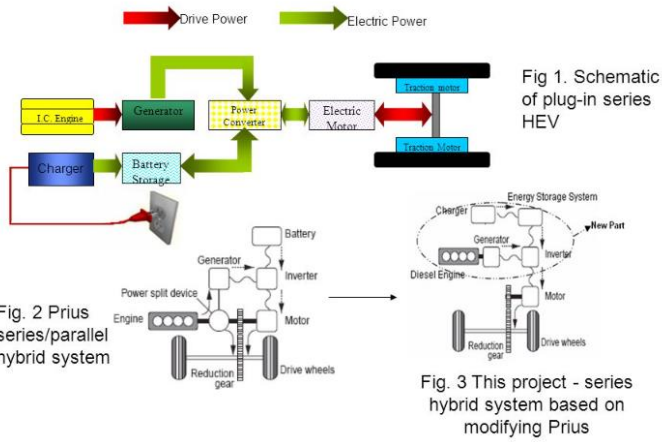

[Control of a parallel hybrid powertrain: optimal control | Semantic Scholar](https://www.semanticscholar.org/paper/Control-of-a-parallel-hybrid-powertrain%3A-optimal-control/11254444-1125-4444-1125-4444)

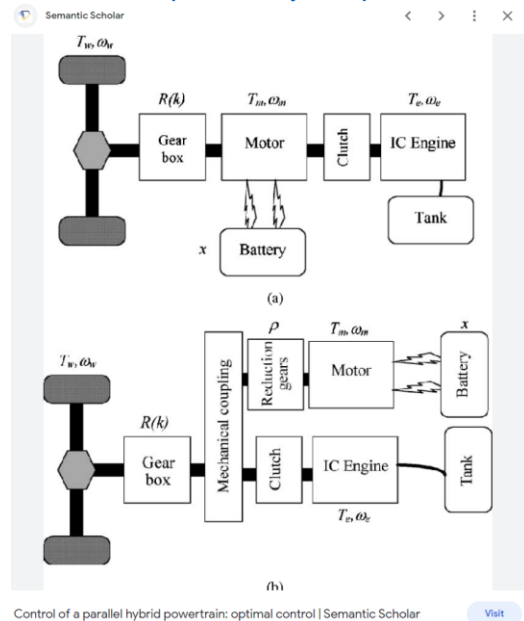

Control of a parallel hybrid powertrain: optimal control | Semantic Scholar

Visit

TECHNOLOGICAL AND SERVICE ORIGINALITY

Nikola One is a technological phenomenon, not only because of the electric propulsion and combined provisions of battery-derived electricity and fuel cells, but also because of numerous design and content idiosyncrasies. Among the most conspicuous is the cabin, designed to provide better aerodynamic properties.

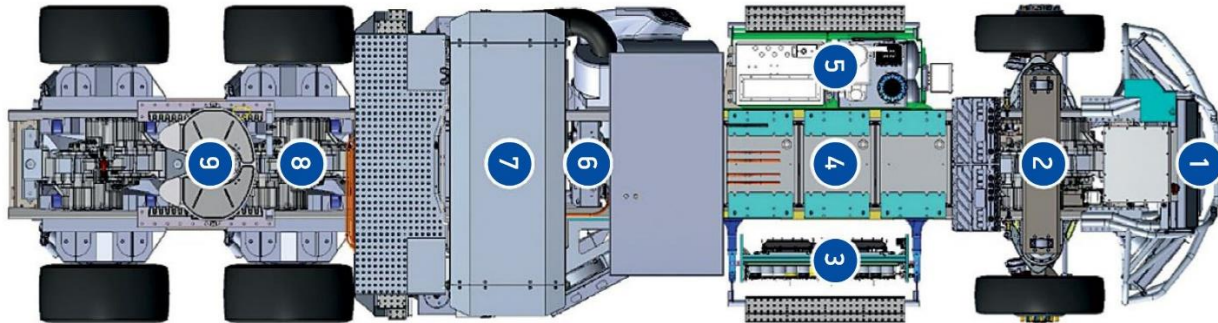

An assembly of radiators and motor cooling units, fuel cells, transmissions, batteries and a cabin 2 – an assembly of the front two electric motors and transmissions 3 – power-electronics in control of fuel cell operation and battery charging 4 – battery storage system of 32,000 individual Li-ion cells with total capacity of 320 kWh 5 – chiller providing cold fluid to cool the batteries and air tanks for backup disc brakes 6 – fuel cells with 300 kW output 7 – hydrogen tanks 8 – load-bearing housing with suspension for a reardrive electric motor and gearboxes 9 – aluminum coupling for connecting a semi-trailer

[UPS adding 200 more series hybrid delivery trucks - Green Car Congress](#)

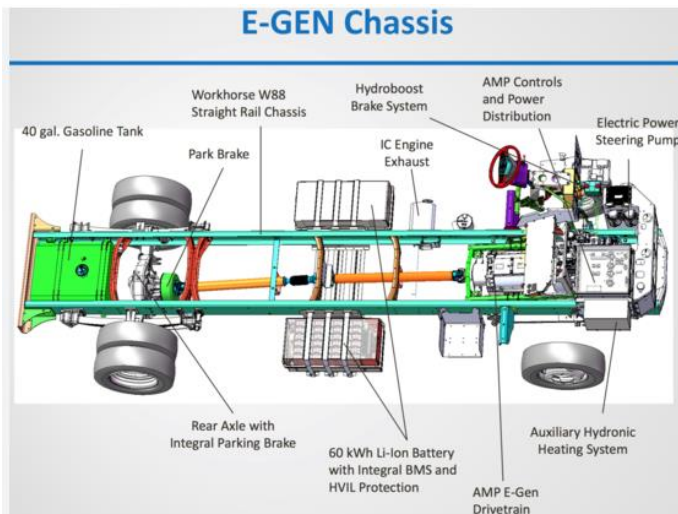

Dual fuel combustion and hybrid electric powertrains as potential solution to achieve 2025 emissions targets in medium duty trucks sector - ScienceDirect

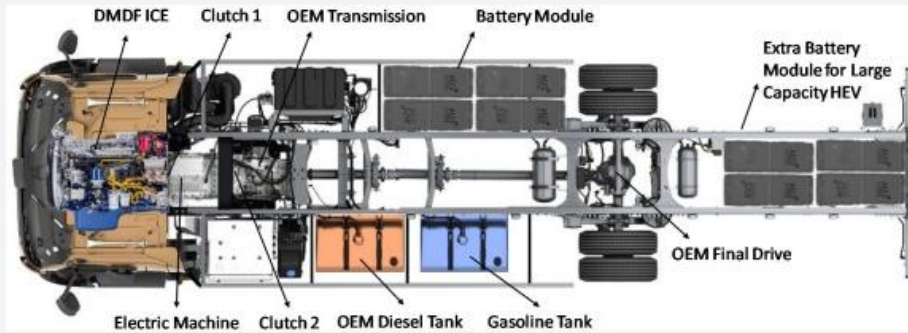

Dual fuel combustion and hybrid electric powertrains as potential solution to achieve 2025 emissions targets in medium duty trucks sector - ScienceDirect

A2

Compound Electric Hybrid. (<https://t20e.net>)

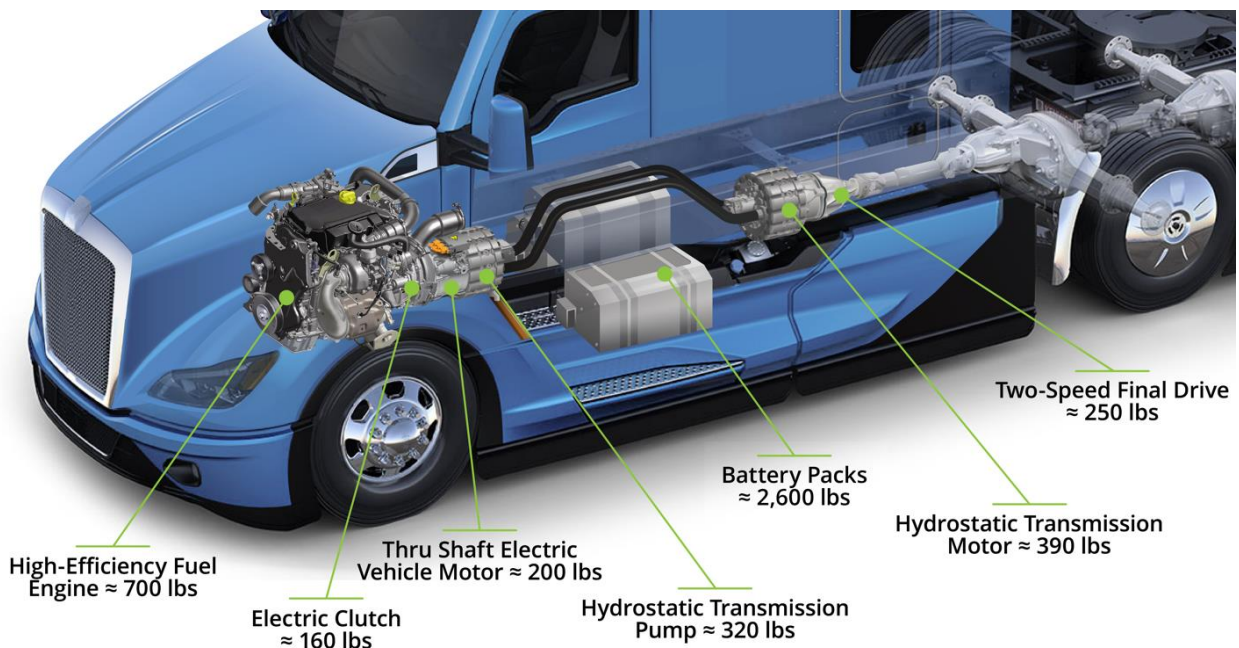

A3

[550A DC ME102 Double-Shafted Motor | Electric Car Parts Co \(electriccarpartscompany.com\)](#)



[Net Gain Warp 11 DC EV Motors | Electric Car Parts Co \(electriccarpartscompany.com\)](#)

72-156V 453A
Double Ended Shaft



WarP 11 EV DC Motor 72-156V, 453A Double
Ended Shaft

B1

[Inception Drive: A Compact, Infinitely Variable Transmission for Robotics - IEEE Spectrum](#)

In an [infinitely variable transmission](#) (IVT), which is a specific kind of [continuously variable transmission](#), the transmission ratio includes a zero point that can be approached from either a positive side or a negative side. In other words, a constant input, like an electric motor turning the same direction at the same speed, can be converted to an output that's turning faster, turning slower, turning in the opposite direction, or not turning at all (in this “geared neutral” mode, you’d need infinite input revolutions to cause one output revolution, hence the name “infinitely variable transmission”).

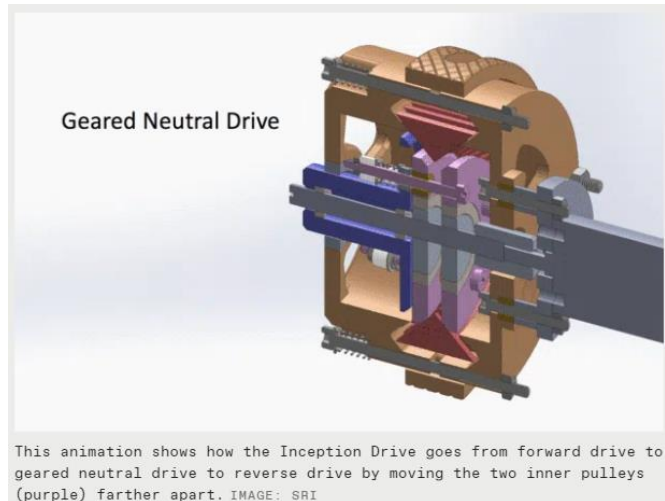

[Transmission, Infinitely Variable Transmission \(IVT™\) \(deere.com\)](#)



The revolutionary Infinitely Variable Transmission (IVT) provides excellent performance in all farming conditions. The John Deere IVT is an easy transmission to use, with simple and intuitive controls allowing you to move smoothly from 0.03 mph (50 meters/hr.) up to optional 31 mph (50 km/hr.) and any speed in between. Never again is a gear too fast or too slow; the IVT provides a seamless range of speeds with no gaps. No clutching is required to start or stop the tractor. The footbrake with integrated AutoClutch performs like the brake in a car; simply depress both brakes and the transmission ratios down to a stop from any ground speed. To keep your 8030 Series Tractor stationary even on inclines, use the John Deere-exclusive PowerZero™ feature.

The 8030 Series IVT offers a choice of two control strategies: a right-hand reverser control (order codes 1127 or 1167) and a left-hand reverser control (order codes 1137 or 1157).

B2

<https://spectrum.ieee.org/inception-drive-a-compact-infinitely-variable-transmission-for-robotics>

In an infinitely variable transmission (IVT), which is a specific kind of continuously variable transmission, the transmission ratio includes a zero point that can be approached from either a positive side or a negative side. **In other words, a constant input, like an electric motor turning the same direction at the same speed, can be converted to an output that's turning faster, turning slower, turning in the opposite direction, or not turning at all** (in this “geared neutral” mode, you'd need infinite input revolutions to cause one output revolution, hence the name “infinitely variable transmission”).

<https://www.powermotiontech.com/hydraulics/hydraulic-pumps-motors/article/21883458/hydrostatic-transmissions-a-power-play-in-wind-turbine-design>

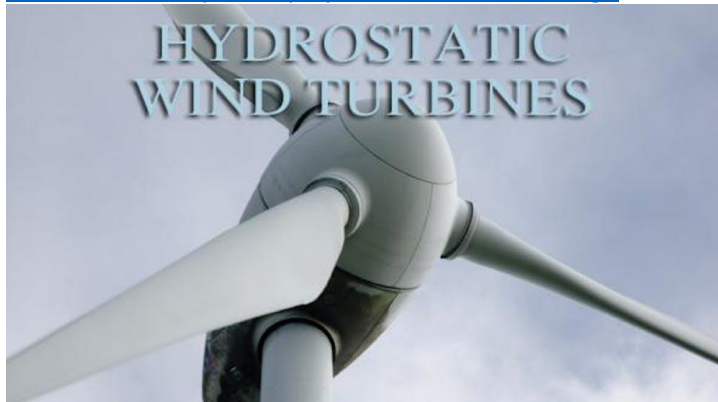

An innovative concept replaces the common gearbox and frequency converter in conventional wind turbines with a hydrostatic drivetrain using fixed-displacement pumps and fixed and variable-displacement motors.

[Johannes Schmitz, Nils Vatheuer, Hubertus Murrenhoff | RWTH Aachen University, IFAS](#)

Today, two different types of turbines dominate the market, both employing a three-bladed rotor with a horizontal axle of rotation. The first uses a mechanical transmission to transfer the slow-turning shaft of the turbine rotor into a higher rotational speed to drive a generator. The second doesn't require mechanical transmission — a huge generator directly uses the high torque and converts it to electrical energy. In both cases, the generator's rotation — and, therefore, the frequency of the electricity produced — are coupled with the turbine.

A major issue with these designs is that the turbine's variable rotation speed requires a frequency converter to connect each turbine to the power grid. Other issues include reliability problems with mechanical gearboxes and the weight of the directly driven generator due to increasing turbine sizes.

A new concept — transferring power via a hydrostatic drivetrain — combines good efficiency and grid stability with high reliability and low costs. In a research project funded by the Federal Ministry for the Environment, Nature Conservation, and Nuclear Safety of Germany, the Institut für

Angewandtes Stoffstrommanagement (IFAS), Hamburg, developed a prototype of a hydrostatic transmission for 1-MW power-class wind-energy plants that's intended to replace the commonly used gearbox and the frequency converter.

The basic design employs a slow-turning pump connected to the turbine shaft to transfer the power into a high-pressure oil flow. Hydraulic motors then convert the oil flow back into mechanical power to drive a generator. The high transmission ratio needed in a turbine can easily be achieved by the displacement ratio of the pump and motor. Using a variable-displacement motor allows varying transmission ratio so that the generator runs at constant speed.

[Engineering Essentials: Hydrostatic Transmissions | Power & Motion \(powermotiontech.com\)](#)

HSTs offer many important advantages over other forms of power transmission. Depending on its configuration, an HST:

- transmits high power in a compact size
- exhibits low inertia
- operates efficiently over a wide range of torque-to-speed ratios
- maintains controlled speed (even in reverse) regardless of load, within design limits
- maintains a preset speed accurately against driving or braking loads
- can transmit power from a single prime mover to multiple locations, even if position and orientation of the locations changes
- can remain stalled and undamaged under full load at low power loss
- does not creep at zero speed
- provides faster response than mechanical or electromechanical transmissions of comparable rating, and
- can provide dynamic braking.

[Hybrid Electric Powertrains Helping Decarbonize Marine and Offshore Applications | Power & Motion \(powermotiontech.com\)](#)

https://www.powermotiontech.com/technologies/article/21240550/hybrid-electric-powertrains-helping-decarbonize-marine-and-offshore-applications?oly_enc_id=7384C4961023C3R

C1

[Boosting Fuel Economy With the "Sweet Spot" | Go By Truck Global News \(gobytrucknews.com\)](https://gobytrucknews.com)

Big rigs are among the biggest gas guzzlers on the road. With gas prices and environmental concerns rising, federal agencies are being tasked with finding new ways to improve fuel efficiency for our nation's largest vehicles. Of course, drivers and trucking companies have a real stake in reducing fuel costs as well. Fuel makes up the largest expense for drivers and eats away at profits.

To curb fuel consumption, drivers are often advised to slow down and find the "sweet spot." **The sweet spot refers to the ideal RPM at which an engine should be running for maximum fuel efficiency.** Most owner's manuals list the ideal range or sweet spot for a particular engine, which could be anywhere from 1,200 to 1,500 RPMs.

[Sweet spot refinement \(techno-fandom.org\)](https://techno-fandom.org)

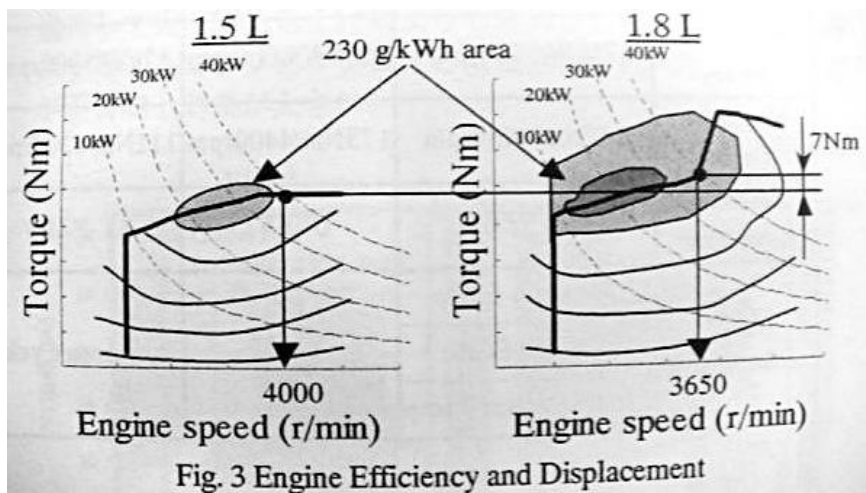

This is called a brake specific fuel consumption or BSFC graph, and here two of them are shown together comparing the second-generation and third-generation Prius engines respectively. The "brake" part simply implies a somewhat idealized laboratory power measurement, often done with some means of applying a braking force to a test engine and letting it push against that to generate heat, electricity, or whatever while measurements are taken. The key part here is "fuel consumption", and that has an interesting relationship to torque and speed. Almost all BSFC charts have this general appearance, with torque plotted against RPM and a set of roughly concentric regions, similar to how elevation contour lines are indicated on a topo map, indicating the fuel consumed per unit power/energy output under differing sets of running conditions. This is often given in fuel grams per kilowatt-hour, all units of energy. The higher one climbs on the topological "mound" represented by the fuel consumption lines, the less fuel is burned to obtain a certain power. The top of the mound represents the most ideal conditions, e.g. **the theoretical "sweet spot"** for an engine. The mound's location varies a bit depending on engine design; some

other examples for different production engines can be found at Ecomodder, a good general explanation from Autospeed, and more about the theory may reside in a Wikipedia article.

C2

Weichai, Bosch Claim Efficiency Breakthrough

By Mike Brezonick | 16 September 2020

👁 3 min read

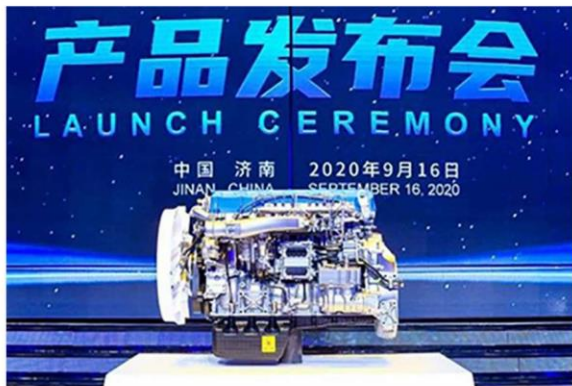

Brake thermal efficiency of 50.26% achieved for Weichai 13 L truck diesel

Chinese engine manufacturer Weichai Power and Bosch announced what the two companies called “a huge leap forward in engine technology.” The companies said they have successfully increased the brake thermal efficiency of Weichai diesel engine for heavy commercial vehicles to over 50%, setting a

new global benchmark.

[Nissan Working on Engine With 50-Percent Thermal Efficiency \(roadandtrack.com\)](https://roadandtrack.com)

"In a conventional engine, there are restrictions on controlling the air-fuel mixture's dilution level to respond to changing driving loads, with several trade-offs between various operating conditions, such as in-cylinder gas flow, ignition method, and compression ratio which can sacrifice efficiency for power output," Nissan said in a press release. **"However, a dedicated engine running at an optimal range of speed and load for electrical generation makes it possible to dramatically improve thermal efficiency."**

C3

[Turbine trucks? 50 years ago, we got behind the wheel | FleetOwner](#)

FORD 705 TURBINE ENGINE

Cutaway (3/4 rear view) of Ford 705 engine shows secondary combustor, output reduction gears. (Click photo to enlarge)

The Ford turbine is a two-stage compression, intercooled, reheat/regenerative cycle type. It's rated at 600 hp. @3080 rpm with 560 net shaft hp. at 3080 rpm with allowance for accessory loads. Torque is 955 lbs.-ft. at 3080 rpm and 1,620 lbs.-ft. at stall. The engine measures 49 in. long, 44 in. wide and 38 in. high. It weighs 1,475 lb.

The 705, Ford engineers report, has a unique feature: it is supercharged with two stages of compression using centrifugal compressors with air-to-air intercooling. This allows the engine to use less air, gives excellent fuel economy throughout its operating range and employs smaller parts running at high speeds.

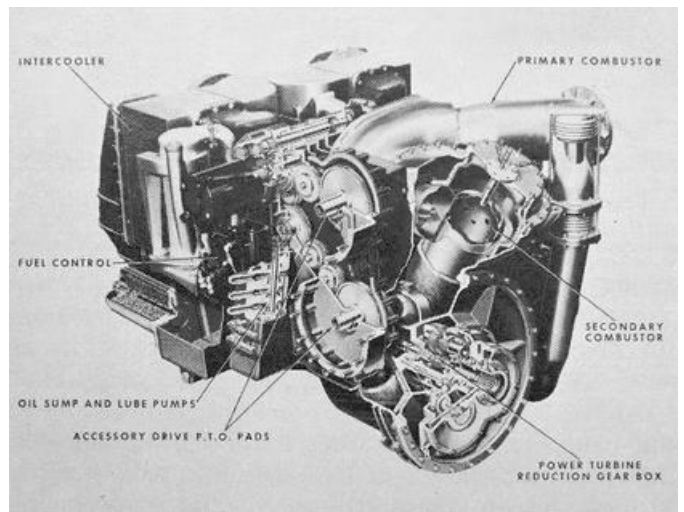

D1

[Tesla Model 3 Drive Unit with controller \(evshop.fr\)](#)

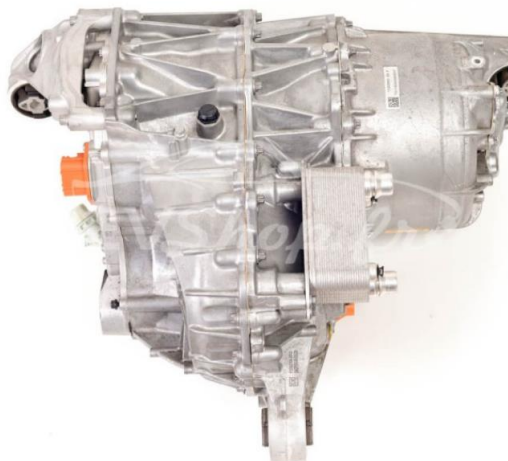

https://www.tesla.com/ownersmanual/model3/en_cn/GUID-E414862C-CFA1-4A0B-9548-BE21C32CAA58.html

Cars manufactured in the U.S.:

Motor Type	Max Power
3D1	202 kW @ 5000 rpm
3D3	137 kW @ 6380 rpm
3D5	180 kW @ 6000 rpm

D2

Calculate 86,000 lb/ft starting axle torque using 334cc Hydrostatic motor drive unit:

3.85	Dif-ratio	Differential drive ratio for end of truck drivetrain to Axle output
40.0	dia. inches	Tire diameter size from radius
504.2	turns/mile	# of revolutions the axle makes with these tires for each mile of travel (5280 feet per mile / circumference of tire in feet)
80.0	top MPH	Truck top speed spec'd limit for passing on highway while maintaining full HP output through HST
672.3	RPMa	Axle RPM to achieve this top passing speed as specified (Top MPH * turns per mile / 60)
1,460	Torque lb./ft	TQ from 334cc HST motor at full displacement and while at full operational pressure of 5,400psi
3.48	High gear ratio	Final Drive high-gear-ratio for output to the Axle differential gearing (max HST rpm / axle rpm / differential ratio)
4.40	Low gear ratio	Final Drive low gear (drop gear ratio) For the Final Drive 2 speed low gear compounding option
1,800	HST RPM low	RPM minimum for Hydrostatic motor to achieve full power output
9,000	HST RPM high	Top HST RPM at full power output and reduced displacement resulting in HST overall ratio
20%	min-disp %	HST motor minimum displacement % at full power output (minimum rpm's / max rpm's ... at full power output)
5.0	HST ratio	HST motor full power output ratio from min. to max. displacement Full displacement @ high RPM's to the rated min. displacement @ RPM's. (HST highest RPM / Minimum RPM while staying at full power output)
16.0	MPH high gear b	Lowest speed of Truck using the top gear of 2 speed final drive while maintaining full power output (top speed @ full output HP / ratio of HST motor)
18.2	MPH low gear top	Top speed in underdrive low gear of 2 speed final drive (top MPH / lower gear ratio)
2.2	overlap MPH	MPH overlap between Low Gear and High gear of 2 speed final drive during shifting between the 2 gears at maximum output & speed
3.64	MPH low gear bot	Speed of truck using Low Gear selection from 2 speed final drive While still maintaining maximum breakaway torque below And from here starts full horsepower throughput applied from HST (Top gear full power low speed / low gear at ratio specified)
500	HPm	Horsepower output of 334cc HST motor operating at full power ratio $HP = (RPM * TQ) / 5252$
86,001	Torque lb./ft	Axle Torque output maximum at startup and breakaway at Axle with Final Drive compounding in low gear for max breakaway & startup force using the 2 speed final drive lower ratio to compound with upper ratio (HST tq * ratio final high gear * ratio underdrive compound gear * ratio rear end)

D3

Calculate the Kilowatts for Electric Motor power needed for the following parameters during Freight Truck transportation:

Crr	0.006	Crr	Coefficient of rolling resistance
Cd	0.500	Cd	Coefficient of Aerodynamic Drag
W	70,000	Weight	GVW figured with load total weight
A	114.0	sq ft area	Frontal area total sq ft.
E	82.0%	%	Efficiency of Drive Train from motor to axle hubs
R	20.0	in. radius	Tire Radius being used
p	0.002378	Slugs/ft ³	Air density at sea level
	0.10%	%	% slope for uphill Grade
θ	0.057	degrees	equivalent angle degrees for % slope of grade
	60.0	mph	Speed of Truck on highway
V	88.002	ft/sec	velocity of vehicle conversion..... MPH*1.4667 ft/s per mph
	10.47		circumference of tires in feet
	5280.0		total distance in feet for one minute of travel at above speed MPH
	504.2		distance in feet divided by feet of circumference for RPM of axle
RPMa	504.2	RPMa	Axle RPM's at speed of truck with Tire Radius above
Hw	10.0	MPH	Headwind MPH
Vh	14.667	ft/sec	velocity of headwind conversion..... MPH*1.4667 ft/s per mph
Step 1: Calculate Rolling Resistance force (Fr):			
			...Fr = Crr * W
(Fr)	420.0	lb. force	
Step 2: Calculate Aerodynamic Resistance force (Fa):			
			...Fa = 0.5 * Cd * A * p * V ²
V ²	7744.4		
(Fa)	524.9	lb. force	
Step 3: Calculate Aerodynamic Force from Head wind (Fw):			
			...Fw = 0.5 * Cd * A * p * Vh ²
Vh ²	215.1		
(Fw)	14.6	lb. force from headwind	
Step 4: Calculate Gravitational Force from uphill grade (Fg):			
			... Fg=W*sin(θ)
(Fg)	70.0	lb. force	
Step 5: Total of Resistance Force from all the above (F):			
			...F = Fr + Fa + Fw + Fg
(F)	1029.4	lb. force	
Step 6: Torque needed compute for the axle using Tire radius (Ta):			
			...F * R
(Ta)	1715.7		
Step 7: Horsepower at Axle (HPa):			
			... HP = (RPMa * Ta)/5252
(HPa)	164.7		
Step 8: Horsepower at motor needed for drivetrain efficiency (HPm):			
			... Hap / E
(HPm)	200.9		
Step 9: Conversion HP to Kilowatts (KWm):			
			...HPm / 1.33
(KWm)	151.0		

<https://t20e.net>

In addition to above calculation for 151 KW motor ...

To find Motor power needed using an Electric Motor in a Semi truck - as estimated per below with averaging 2.5 KW per mile:

Finding the power (in kilowatts) of the electric motor for an electric truck that consumes 2.5 kW per mile and travels at 60 miles per hour:

Power (KW) = Consumption Rate (KW/mile) * Velocity (miles/hour)

- Consumption Rate = 2.5 kW/mile
- Velocity = 60 miles/hour

Power (KW) = 2.5 kW/mile * 60 miles/hour = 150 kW

So, the power rating of the electric motor is 150 kilowatts.

<https://engsfinance.com/blog/the-true-cost-of-electric-semis-how-do-they-compare-to-traditional-diesel/>

COST OF FUEL

Electricity is cheaper than diesel, and electric trucks don't require the same level of maintenance as their diesel counterparts. Electric trucks also have regenerative braking, which helps to extend the life of the brakes as well as extend the range per charge in certain instances. When you figure the average mileage is 7mpg for a diesel truck, and with the current fuel price surge in the U.S., the national average is \$5.65 per gallon, providing an eye-popping \$0.81/mile in fuel cost alone. **The estimates from most electric semi manufacturers is between 2 and 2.5KWh per mile, and the current range of electricity pricing is \$0.12- \$0.20/KWh**, an electric truck can be easily \$0.50/mile cheaper to run. When you factor in all of these cost-savings, electric semis start to look a lot more attractive from a TCO perspective.

(FSP: savings only until they road tax the electricity and figure in cost of a charging depot amortized plus infrastructure cost amortized).

Emailed newsletter 11:07 from newsletter@babcoxmediaeditorial.com

There's no magic bullet technology that made this level of trucking fuel efficiency possible. It's a collection of design refinements, equipment enhancements, and product innovation that made it possible. **One of the standouts is the International SuperTruck's hybrid powertrain.** Oppermann explained that the SuperTruck 2 program's primary focus was on brake thermal efficiency in the engine, as well as improvements on the vehicle side. Navistar engineers **merged a hybrid system featuring an electric motor outputting around 150 kilowatts**, backed by a 30-kilowatt battery, with International's S13 13-liter engine.

D4

<https://www.racefans.net/2021/11/11/how-f1-can-push-the-worlds-most-efficient-engine-even-further/>

The figure that F1 has issued for the current power units' overall efficiency is 52%, which is a staggering amount compared to average petrol engines making about 20% thermal efficiency. That includes the hybrid recovery system and is a huge increase, compared to 29% at the end of the V8 era. For comparison, the Toyota Prius road-going hybrid has 40% efficiency, itself a huge number for a production car but significantly short of crossing the halfway point of what energy is in the fuel burned and what energy is output by the engine.

[Marvelous Formula 1 engines – Society of Automotive Engineers \(wordpress.com\)](#)

Marvelous Formula 1 engines

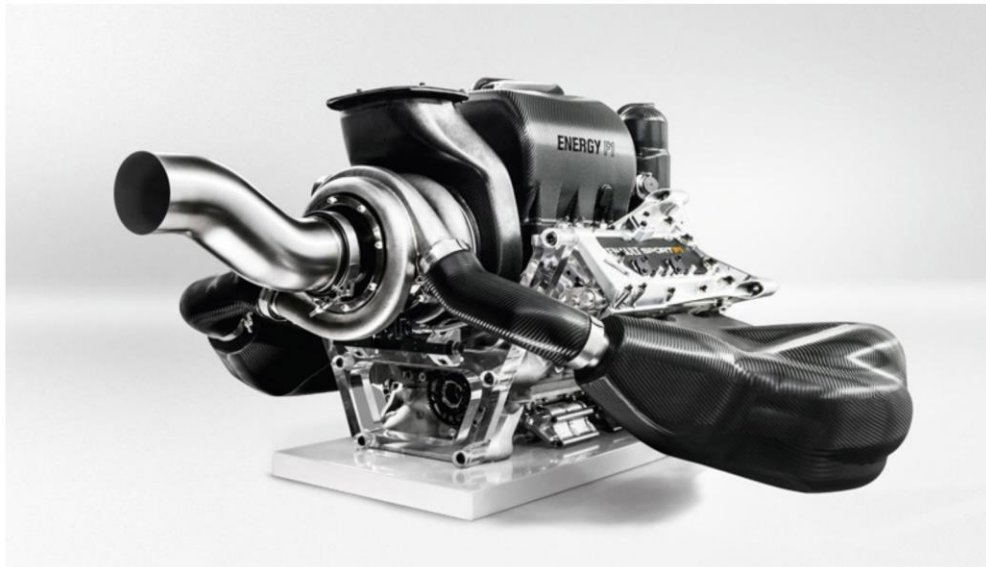

D5

**Battery Capacity (kWh)
as a function of Energy Consumption and Range**

Energy Consumption (kWh/mi)	Range (mi)			
	50	100	150	200
1.0	50	100	150	200
1.2	60	120	180	240
1.4	70	140	210	280
1.6	80	160	240	320
1.8	90	180	270	360
2.0	100	200	300	400
2.2	110	220	330	440
2.4	120	240	360	480
2.6	130	260	390	520
2.8	140	280	420	560
3.0	150	300	450	600

Figure 7. Battery capacity kWh as a function of consumption and range

An example of using the chart, if the manufacturer’s specification sheet states there is a 400 kWh battery pack with an estimated range of 200 miles, then the estimated consumption is 2 kWh/mi. Alternatively, if consumption is known to be 2.2 and the range is estimated as 100 miles, then the useable battery pack capacity is estimated as 220 kWh.

**Battery Weight (lb)
as a function of Energy Density and Battery Capacity**

Energy Density (lb/kWh)	Battery Capacity (kWh)									
	100	200	300	400	500	600	700	800	900	1,000
5.0	500	1,000	1,500	2,000	2,500	3,000	3,500	4,000	4,500	5,000
10.0	1,000	2,000	3,000	4,000	5,000	6,000	7,000	8,000	9,000	10,000
15.0	1,500	3,000	4,500	6,000	7,500	9,000	10,500	12,000	13,500	15,000
20.0	2,000	4,000	6,000	8,000	10,000	12,000	14,000	16,000	18,000	20,000
25.0	2,500	5,000	7,500	10,000	12,500	15,000	17,500	20,000	22,500	25,000
30.0	3,000	6,000	9,000	12,000	15,000	18,000	21,000	24,000	27,000	30,000

Figure 8. Battery weight (lbs.) as a function of energy density and range (NACFE)

E1

<https://www.tractor-specs.net/farmall/frmall-656.html>



The **Farmall 656** is a 2WD row-crop tractor manufactured by Farmall (a part of International Harvester) from 1965 to 1973.

The Farmall 656 is equipped with one of two engines: a 4.3 L (263.0 cu in) six-cylinder gasoline/LP-gas engine or a 4.6 L (282.0 cu in) six-cylinder diesel engine and one of three transmissions: a gear type transmission with 5 forward and 1 reverse gear, a two-speed power shift transmission with 10 forward and 2 reverse gears or a hydrostatic transmission with infinite (2-range) forward and reverse gears.

https://global.kawasaki.com/en/industrial_equipment/hydraulic/systems/hst.html

Hydrostatic Transmission (HST) System

Hydrostatic Transmission system provides smooth and efficient power transmission by connecting the hydraulic pump and motor in a closed circuit. This system is widely used for the traveling function of many construction machinery and agricultural machines.

The Hydrostatic Transmission (HST) System can be utilized on the applications that require high torque output at low driving speed or repeat reversing direction such as the wheel loaders, dozers, telehandlers, or combine harvesters and enables smooth driving speed adjustment without operating the gear shift.



https://www.google.com/books/edition/Advanced_Hybrid_Powertrains_for_Commerci/OuKbEAA_AQBAJ?hl=en&gbpv=1

3.8.2. Hydrostatic CVT

Another type of CVT, known as a hydrostatic CVT, uses variable-displacement pumps to vary the fluid flow into hydrostatic motors. In this type of transmission, the rotational motion of the engine operates a hydrostatic pump on the driving side. The pump converts rotational motion into fluid flow. Then, with a hydrostatic motor located on the driven side, the fluid flow is converted back into rotational motion.

Often, a hydrostatic transmission is combined with a planetary gear set and clutches to create a hybrid system known as a hydromechanical transmission. Hydromechanical transmissions transfer power from the engine to the wheels in three different modes. At a low speed, power is transmitted hydraulically, and at a high speed, power is transmitted mechanically. Between these extremes, the transmission uses both hydraulic and mechanical means to transfer power. Hydromechanical transmissions are ideal for heavy-duty applications, which is why they are common in agricultural tractors and all-terrain vehicles.

The basic structure of the hydromechanical transmission is to use one planetary gear set as the differential mechanism, which includes input split and output split. The input split is the combination of hydraulic motor and output shaft at a constant speed ratio, as shown in Figure 3.22. Output split is the combination of hydraulic pump and input shaft at a constant speed ratio. Fundamentally, they are the same mechanism. The split type is determined by which shaft is input or output.

The hydromechanical transmission can be linked to a hydraulic accumulator to adjust the amount of power flow through the hydraulic path, as opposed to the mechanical path. It is especially useful for regenerative hydro-mechanical drivetrains for the application of hydraulic hybrids to enable the engine speed and vehicle velocity to be independent. Various configurations of hydraulic power generation, storage, and usage can be implemented for optimized vehicle drivability and fuel savings.

FIGURE 3.22 Schematic of input-split hydrostatic transmission.

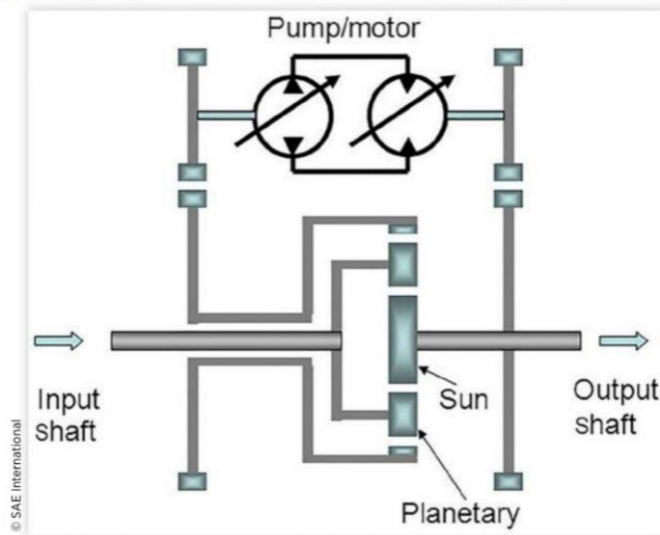

E2

<https://www.ivtinternational.com/news/engines/sai-develops-off-highway-hydrostatic-transmission.html>



SAI develops off-highway hydrostatic transmission

SAI's latest variable displacement technology is helping to revolutionize the design of hydrostatic transmission systems, optimizing performance, weight, noise and overall efficiency.

In all mobile machinery, energy must be transferred from the prime mover (usually a diesel engine) to the end users – either the wheels to drive the machine or the tools and equipment installed.

When using a hydrostatic transmission, the operational performance maximum tractive effort (torque) and travel speed of the machine is defined by the pump, the motor and the mechanical setup.

The SAI variable displacement radial piston motor can transition seamlessly from maximum to minimum displacement, for complete motor speed and torque control. The motor can be used with a minimum displacement 10% of the maximum displacement, while still offering high efficiency and controllability.

This offers the capacity to cover the full required range of the machine simply by adjusting the pump output flow and the SAI variable displacement motor, without adding gear switches, clutches, or any other form of mechanical transmission.

High accuracy, low emissions

The SAI variable displacement motor provides high levels of efficiency, from creep speed in maximum displacement, to top speed in minimum displacement. This innovative solution is favored over the traditional gearbox/motor combination as the efficiency of the drive is greatly increased by decreasing the gearbox reduction ratio.

The SAI motor gives direct access to the machine's whole operational range. The efficiencies achieved result in reduced fuel consumption and power losses – a critical factor for meeting stricter emissions regulations.

The high efficiency throughout the entire displacement variation range results in very accurate power delivery, from very low-speed positioning to very high-speed travel.

E3

<https://www.gfrindustries.com.au/single-post/2019/09/01/gfr-industries-hydro-static-driven-truck-drives-and-blower-systems-by-omsi-and-gfr-indust>

Did you know we can drive your truck at 2 kph under full load ? Using the OMSI Hydro Static drive we can smooth down and make your operation safer .



OMSI Split Shafts Distributed By GFR Industries in Australia

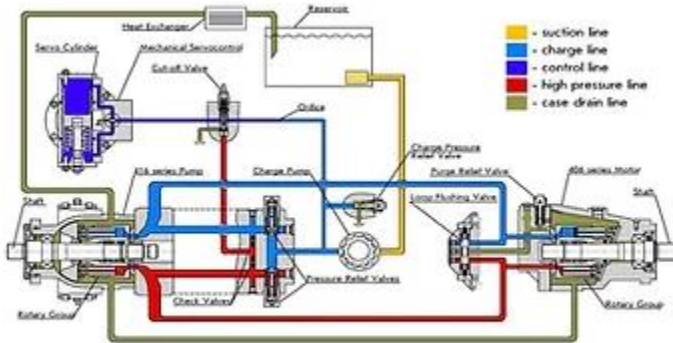

E4

Emailed newsletter 11:07 from newsletter@babcoxmediaeditorial.com

(uses some hybrid electric technology)

How the International SuperTruck 2 makes 16 MPG a reality.



Thirteen miles per gallon was the high water mark the last time the SuperTruck program brought cutting-edge demonstration trucks to America's highways in 2016. This year, International's SuperTruck 2 reached even further, **hitting 16 MPG** in flatland duty cycles across Illinois with a 65,000-lb. gross vehicle weight, according to Dean Oppermann, chief engineer of advanced truck at Navistar.

There's no magic bullet technology that made this level of trucking fuel efficiency possible. It's a collection of design refinements, equipment enhancements, and product innovation that made it possible. **One of the standouts is the International SuperTruck's hybrid powertrain.** Oppermann explained that the SuperTruck 2 program's primary focus was on brake thermal efficiency in the engine, as well as improvements on the vehicle side. Navistar engineers **merged a hybrid system featuring an electric motor outputting around 150 kilowatts**, backed by a 30-kilowatt battery, with International's S13 13-liter engine.

In practical terms, the electric motor can power the powertrain and start the engine, effectively facilitating power transfer in both directions. The setup allows the **electric power to be utilized more efficiently at stops, enabling higher torque for better launches.** As the vehicle reaches a specific speed or load, the system switches from electric to diesel operation.

F1

https://www.transportationenergy.org/wp-content/uploads/2023/07/Decarbonizing-Combustion-Vehicles_Summary-of-Findings.pdf



Summary and Conclusions

- There is no single solution for decarbonizing the on-road transportation sector
- ICEVs will comprise a significant portion of the fleet well into the future, despite policy efforts to accelerate a transition to new vehicles
- GHG emissions accumulate and remain in the atmosphere for more than 100 years –
 - Early emissions reductions is critical to achieving environmental objectives
 - This necessitates lowering the carbon emissions from ICEVs and not waiting for the market to transition to new vehicles
- Carbon emissions from the current and future fleet of ICEVs can be reduced through a variety of ways, most notably renewable fuels and ICEV technologies. **Combining low carbon fuels with higher efficiency ICEVs and hybrids increases the GHG reduction potential**
 - There are at least 24 biofuels that can reduce emissions equal to or more than today's EVs charging from the U.S. electricity grid, even when excluding coal power plants from the mix
 - Reducing emissions by up to 15% with existing fuels would remove up to 300 million MT of CO_{2e} emissions each year
- New fuel options being explored and developed today (e.g., pyrolysis, e-fuels, H₂-ICE) show tremendous promise in reducing carbon emissions of ICEVs, but need support to overcome technological, cost and market hurdles.
 - Reducing emissions by at least 40% with innovative fuels would remove 800 million MT of CO_{2e} emissions each year
- Given the varying degrees of viability and timing uncertainties, a portfolio approach to ICEV decarbonization is advisable.
 - A portfolio approach for ICE fuels and future vehicle technologies will result in both ICEVs' (near-term) and ZEVs' (longer term) roles in minimizing transportation carbon emissions being realized.

F2

<https://nacfe.org/wp-content/uploads/edd/2022/05/HD-Regional-Haul-Report-FINAL.pdf>

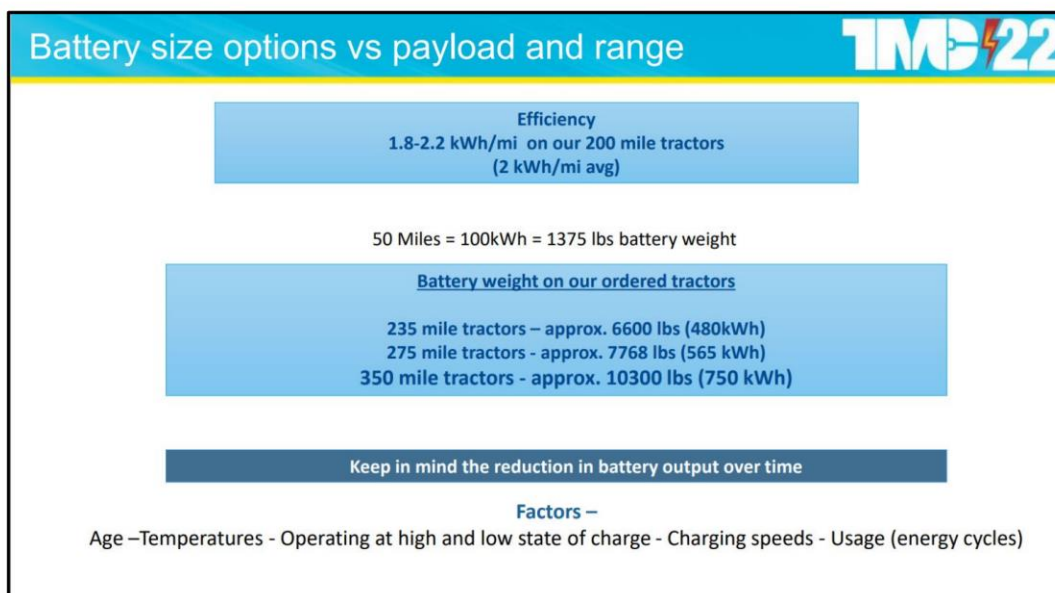

Cost of Fuel

Electricity is cheaper than diesel, and electric trucks don't require the same level of maintenance as their diesel counterparts. Electric trucks also have regenerative braking, which helps to extend the life of the brakes as well as extend the range per charge in certain instances. When you figure the average mileage is 7mpg for a diesel truck, and with the current fuel price surge in the U.S., the national average is \$5.65 per gallon, providing an eye-popping \$0.81/mile in fuel cost alone. The estimates from most electric semi manufacturers is between 2 and 2.5KWh per mile, and the current range of electricity pricing is \$0.12-\$0.20/KWh, an electric truck can be easily \$0.50/mile cheaper to run. When you factor in all of these cost-savings, electric semis start to look a lot more attractive from a TCO perspective.

(FSP: savings only until they road tax the electricity and figure in cost of a charging depot amortized plus infrastructure cost amortized)

F3

<https://casetext.com/regulation/california-code-of-regulations/title-13-motor-vehicles/division-3-air-resources-board/chapter-1-motor-vehicle-pollution-control-devices/article-2-approval-of-motor-vehicle-pollution-control-devices-new-vehicles/section-19632-advanced-clean-trucks-credit-generation-banking-and-trading>

Section 1963.2 - Advanced Clean Trucks Credit Generation, Banking, and Trading

(b) NZEV Credit Calculation. Until the end of the 2035 model year, a manufacturer may generate NZEV credits for each NZEV produced and delivered for sale in California for the manufacturer-designated model year. NZEV credits are earned when a new on-road vehicle is sold to the ultimate purchaser in California. The NZEV credit generated for each vehicle sold is calculated as the product of the appropriate weight class modifier in Table A-2 of section 1963.1, and the NZEV factor value as calculated in section 1963.2(b) (1).

(1) NZEV Factor Value. The NZEV factor used to calculate NZEV credits shall be calculated as 0.01 multiplied by the all-electric range, and is not to exceed 0.75.

(2) **Minimum All-Electric Range.** To earn credit, NZEVs must have an all-electric range that equals or exceeds the criteria specified in 17 CCR section 95663(d) until the end of the 2029 model year and **an all-electric range that equals or exceeds 75 miles or greater** starting with the 2030 model year.

<https://theicct.org/sites/default/files/publications/CA-HDV-EV-policy-update-jul212020.pdf>

(page 3)

STRUCTURE

The regulation is structured as a credit and deficit accounting system. A manufacturer accrues deficits based on the total volume of on-road HDT sales within California beginning with model year 2024 vehicles. These deficits must be offset with credits generated by the sale of zero-emission vehicles (ZEVs)⁶ or near zero-emission vehicles (NZEVs)⁷ starting in model year 2021. A schematic diagram of this accounting system is shown in Figure 2.

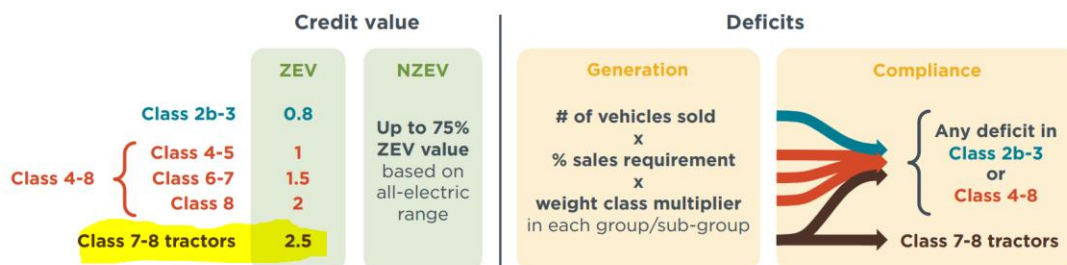

Figure 2: Diagram of credit values, deficit calculation, and regulatory compliance for a manufacturer in a given year.

F4

[Tesla Battery Weight Guide: Tesla Batteries per Tesla Model Answered, Plus Other EV Batteries - In The Garage with CarParts.com](#)

How Heavy Is a Tesla Battery?

The exact **Tesla** battery pack weight varies according to the model. Some **Tesla models** have versions with lighter batteries, reducing their cost in exchange for shorter ranges and lower performance.

The **Model 3** is the company's compact car. First revealed in 2017, the Tesla Model 3 battery weight is around 1,060 pounds (lbs).

Next is Tesla's mid-size luxury crossover SUV offering: the **Model X**. It debuted in 2015, making it older than the Model 3. The Tesla Model X battery weight is 1,183 pounds.

Then you have the **Model S**, a luxury sedan serving as Tesla's flagship vehicle. Initially introduced in 2012 and constantly updated, the Tesla Model S battery weight is around 1,200 lbs.

getjerry.com/car-repair/tesla-model-3-battery-size

Tesla Model 3 battery size, range, and charging specs

The battery size for a brand-new 2023 Tesla Model 3 is either 50 kWh or 82 kWh, depending on the trim level:

- **Single-motor Rear-Wheel Drive (RWD) base trim**
: 50-kWh battery for 272-mile driving range; 8.5-hr charging time at 220V/240V
- **Dual-motor all-wheel Drive (AWD) Performance trim:**
82-kWh battery for 315-mile driving range; 10-hr charging time at 220V/240V
- **Dual-motor AWD Long Range trim:**
82-kWh battery for 358-mile driving range; 10-hr charging time at 220V/240V

F5

<https://nepis.epa.gov/Exe/ZyPDF.cgi?Dockkey=P10178RN.pdf>

(page 25 & 26)

With parallel hybrid designs, the vehicle can be powered in one of three ways: directly by the engine, directly by the electrical motor, or by both systems working together. In parallel hybrid the electric driveline and the combustion engine work together to propel the vehicle, where torque produced by the electric motor and engine crankshaft are blended and combined through couplings, planetary gear sets, or clutches. The choice of using a series or parallel design is dependent on a vehicle's specific application and performance requirements. Several types of motors and generators have been developed for both parallel and series hybrid-electric drive systems, many of which merit further evaluation and development for specific heavy-duty applications and use cases, where the opportunity for reduced CO₂ emissions can be fully realized.

With advances in hybrid technology, some vehicles utilize both series and parallel powertrain design elements (known as "series-parallel" hybrids) where the operation of the two hybrid drive units is controlled by an on-board computer that chooses the most efficient way to operate the vehicle during a given set of speed-load conditions.

Despite the CO₂ reducing potential for hybrids as discussed above, there is no single design solution applicable for all HD vehicle weight classes because each of them is built to satisfy specific customer requirements and use cases, as shown in the examples in Table 1-14. A limited set of hybrid design choices for a given vehicle must be made relative to this range of customer performance requirements and priorities. Challenges in designing a hybrid vehicle's electric motor subsystems (such as the sizing of power electronics and cooling system capacity) must be considered when specifying the power, power density, and cost of the motor assemblies. High-speed electric motors can significantly reduce weight and size of the motor, but they require speed reduction gear sets, which can offset some of the weight savings, reduce reliability, and add cost and complexity. While air-cooled motors are simpler and generally less expensive than liquid-cooled motors, they are also larger and heavier and they require a supply of ambient cooling air, which can carry dirt, water, and other contaminants to the motor. Liquid-cooled motors are generally smaller and lighter for a given power rating, but they may require more complex cooling systems that can be avoided with air-cooled designs. Heavy-duty specific design and development of the hybrid-electric motors, power electronics, regenerative braking system, and control optimization strategies will be needed to fully realize GHG-reducing potential of this technology.

F6

[Nissan Working on Engine With 50-Percent Thermal Efficiency \(roadandtrack.com\)](https://roadandtrack.com)

This engine will be used in a future generation of Nissan's e-POWER system, which is currently employed in the Japanese-market Note. Nissan was able to achieve 50-percent thermal efficiency in testing by essentially tuning the engine to operate within a very specific range of speed and load. Because the engine doesn't drive the wheels, it doesn't have to work with such wide parameters.

"In a conventional engine, there are restrictions on controlling the air-fuel mixture's dilution level to respond to changing driving loads, with several trade-offs between various operating conditions, such as in-cylinder gas flow, ignition method, and compression ratio which can sacrifice efficiency for power output," Nissan said in a press release. "However, a dedicated engine running at an optimal range of speed and load for electrical generation makes it possible to dramatically improve thermal efficiency."